



WEAR BEHAVIOR OF POLYMERIC COMPOUND USING A NEW PLASTIC GEAR TEST RIG

Printed with permission of the copyright holder, the American Gear Manufacturers Association, 1001 N. Fairfax Street, Suite 500, Alexandria, Virginia 22314. Statements presented in this paper are those of the authors and may not represent the position or opinion of the American Gear Manufacturers Association. (AGMA) This paper was presented October 2023 at the AGMA Fall Technical Meeting, 23FTM10

Determining the wear variation of gears made of Ixef® PARA material and demonstrating how the test bench is necessary to characterize plastic gears.

By DR. RICCARDO LONGATO, ENG. CHRISTINE HAMON, and ENG. STEFANO MONTANI

The objective of this work was to validate a methodology to assess the performance of a polymer compound in a gear application with a particular focus on the characterization of the wear behavior of the polymer compound during the gear test.

This article describes how the wear variation of gears made of Ixef® PARA material was determined and demonstrates how the test bench is necessary to characterize the plastic gears.

A case study proposed by the Solvay company for a specific test is described and how the testing activity was carried out to validate the product.

1 INTRODUCTION

The adoption of plastic materials in various engineering applications is increasing more and more [1]. In particular, the use of plastic gears is increasing. These gears are being used in new applications, especially in the automotive sector, where they are chosen for important properties that include:

- ▶ Low mass and inertia.
- ▶ No lubrication required.
- ▶ Corrosion resistance.
- ▶ Sound and vibration damping (NVH behavior).
- ▶ Lower cost for serial production.
- ▶ Short production time per part.
- ▶ Flexible, complex, and highly integrated parts.
- ▶ Lower waste and CO2 production.

We must remember that these types of gears could have also some disadvantages that include:

- ▶ Inferior mechanical properties.
- ▶ Inferior thermal properties.
- ▶ Lower manufacturing tolerances.
- ▶ Lower operating temperature.
- ▶ Moisture absorption.

Every year, new types of materials are produced and, in addition, new fillers such as PTFE for self-lubrication, glass, and carbon fibers are added to the compound to improve its mechanical performance

[2]. The general problem is there is a lack of knowledge about the behavior of such materials in terms of tooth-root failure and wear, which makes it difficult to select the correct type of material to match several different requirements at the same time: for example, the constraint at a given temperature, the difference between dry running and lubricant meshing, and the performance of plastic on plastic or plastic on steel.

This case study is an interesting example of how a plastics company (Solvay) creates a new gear compound to be tested under the conditions required by the end customer (torque, speed, temperature) and with grease lubrication.

The specific test case described in this article can be generalized by showing the test bench built by Longato Srls is certainly necessary not only to perform specific tests requested by the customer but also in general to characterize the new material through the realization of fatigue curves and the determination of wear coefficients to describe the main phenomena studied.

To summarize, this article would like to address the following:

- ▶ Develop and validate a new test rig for gear characterization at high temperature in greased environment.
- ▶ Generate gear wear data on a new material for which literature data is not available.
- ▶ Demonstrate the range of use and applicability of the tested material by integrating chemical resistance tests and post-mortem analysis.

2 TEST RIG DESCRIPTION

The test rig is a non-mechanically closed loop rig, and it was designed using the layout proposed in VDI 2736-4 [3]. (See Figure 1)

The drive motor of the driver gear (steel) is controlled by an encoder to monitor the rotation speed and by a torque meter to check the torque. The same checks are applied to the motor used for the driven gear

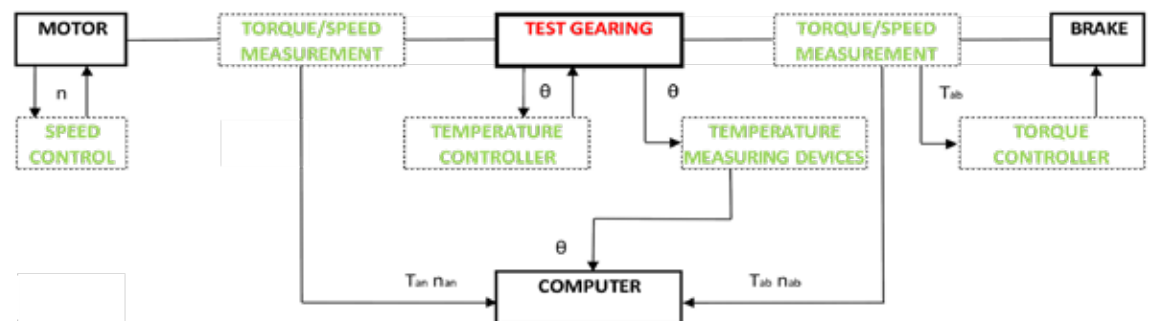

Figure 1: Closed-loop test rig.

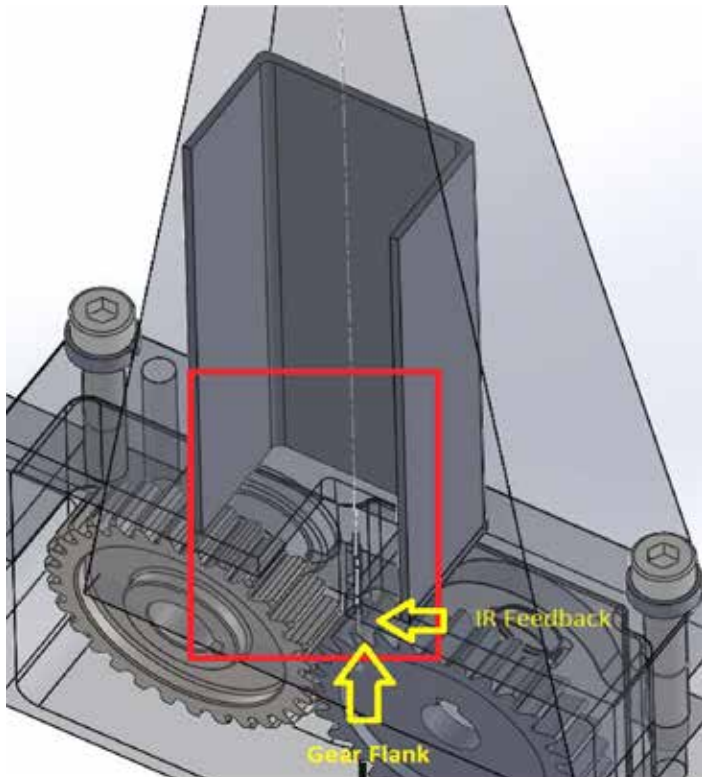

Figure 2: Flank measurement with IR camera.

(plastic, subject to testing), which acts as a brake with re-circulation of electric power to minimize electrical consumption while performing testing.

Checking of rotation and torque allows the rig to stop almost immediately in the event of breakage of a tooth.

The gears are placed inside a climatic chamber to perform testing at a controlled temperature.

The temperature of the plastic wheel can be handled in two different ways: the first involves keeping a constant temperature inside the chamber while the second involves a check of the temperature of the flank or root of the tooth. The testing described later was performed by checking the temperature on the flank of the tooth. (See Figure 2)

The climatic chamber is kept at a constant temperature in counteraction by checking the thermal signals sent by the Optris thermographic IR camera or by the PT100 temperature sensor placed inside the chamber itself. (See Figure 3)

The test rig properties are summarized in Table 1.

3 DESCRIPTION OF SOLVAY PRODUCTS

Solvay has a broad portfolio of high-performance polymers suitable for gear applications. The ultrapolymer compounds of Torlon® PAI and Ketaspire® PEEK can meet very demanding requirements thanks to their excellent thermal, mechanical, and F&W properties. The use of the semicrystalline polymer compounds of Amodel® PPA, Ixef®



Figure 3: PT 100 sensor inserted for grease temperature control.

PARA, and Ryton® PPS are recommended for less demanding and more cost-effective gear applications. These materials show superior chemical, thermal, and mechanical properties and have low water adsorption over more widely used POM or PA46.

4 CASE STUDY

In this article, we present the analysis of the tribological behavior of an Ixef® PARA gear. This material is a 30 percent glass-fiber reinforced polyarylamide compound. It exhibits high strength and rigidity, outstanding surface finish, and excellent creep resistance. (See Table 2)

The chemical resistance test performed on IXEF® PARA against the lubricating grease Multemp SC-U at 140°C shows the excellent polymer stability in temperature and in presence of the lubricant. The mechanical properties of the IXEF® PARA measured at RT are similar when the aging at 140°C is performed with or without grease contact. The chemical stability of the polymer compound in presence of the lubricating grease in temperature is important to ensure continued high mechanical and fatigue properties over the gear lifetime. The chemical degradation can lead to early failure. (See Figure 4)

The gear test is carried out in a climatic cell at a temperature of 100°C, an input torque of 10 Nm, and a rotational speed of 1,000 rpm. The whole system is lubricated by the MULTEMP SC-U grease made by Kyodo Yushi Co, Ltd. In the test we use a steel gear as driving gear and the Ixef® PARA gear (Mn=2) as driven gear. The gear ratio is 1:1.

	Range	Catalogue data		Scale		Theoretical resolution	
Center distance	20 ÷ 150 mm			200	mm	± 0.01	mm
Position/speed	500 ÷ 4000 rpm	20	bit/rev	360	°	0.000343323	°
Torque	0 ÷ 10 Nm	24	bit	50	Nm	2.98E-06	Nm
Thermocouple PT100	-15°C ÷ +150°C	16	bit		°C	0.01	°C
Thermographic camera	-15°C ÷ +150°C	16	bit			Depending on the range of measure	

Table 1: Test rig data sheet.

Properties	Typical value	Test method
Tensile modulus	11500 MPa	ISO 527-2/1A
Tensile stress (break)	190 MPa	ISO 527-2/1A
Tensile strain (break)	2%	ISO 527-2/1A
Flexural modulus	11500 MPa	ISO 178
Flexural stress	285 MPa	ISO 178
Deflection temperature under load 1.8 MPa, unannealed	230°C	ISO 75-2/A
Water adsorption (24h, 23°C)	0.2%	ISO 62

Table 2: Ixef@PARA properties.

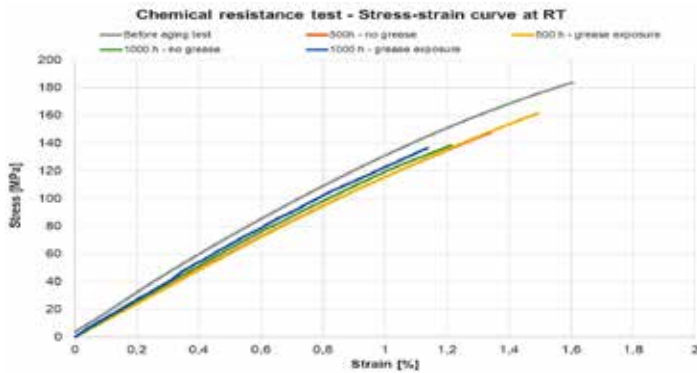

Figure 4: Chemical resistance test.

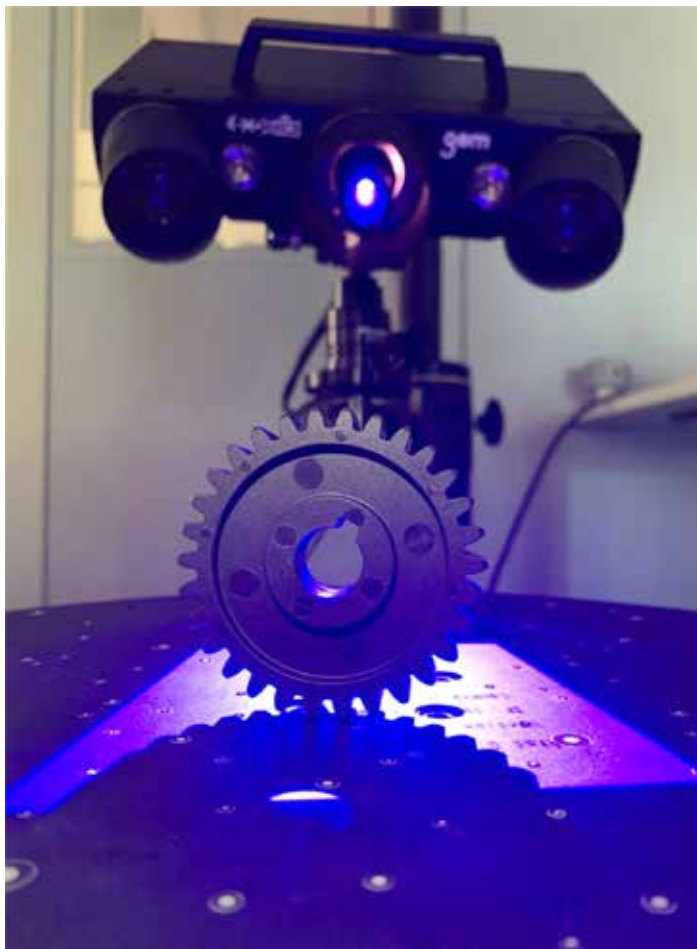

Figure 5: 3D optical scanner.

Symbol	Designation	Unit
W_{ks}	Base tangent length steel gear	mm
W_{kp}	Base tangent length plastic gear	mm
z	Number of teeth	—
x	Profile shift coefficient	—
a_w	Center distance of a cylindrical gear pair	mm
b	Facewidth	mm
B_w	Common face width	mm
d	Reference diameter	mm
F_α	Total profile deviation	μm
F_β	Total helix deviation	μm
F_r	Concentricity deviation	mm
H_v	Degree of tooth loss	—
k_W	Wear coefficient	$10^{-6} \text{ mm}^3/(\text{N}^*\text{m})$
l_{F1}	Profile line length of the active tooth flank	mm
N_l	Number of load cycles	—
T_d	Nominal torque	N^*m

Table 3: Gear geometry symbols.



Figure 6: Component weighing.



Figure 7: Zeiss contact machine.

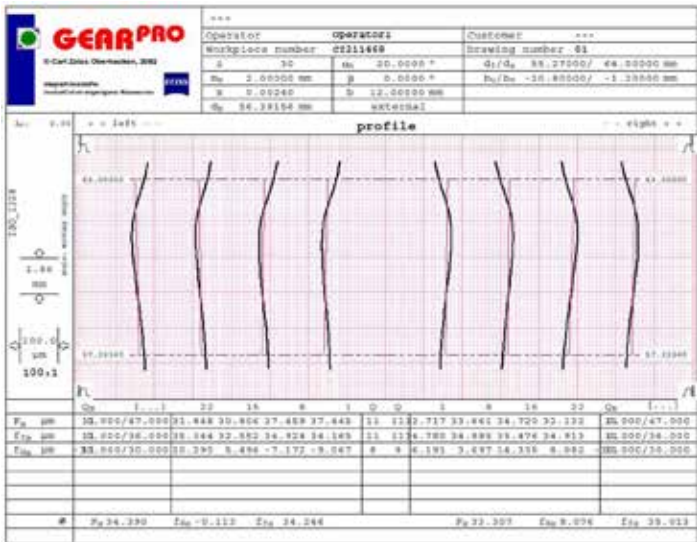

Figure 8: Report of Zeiss machine.

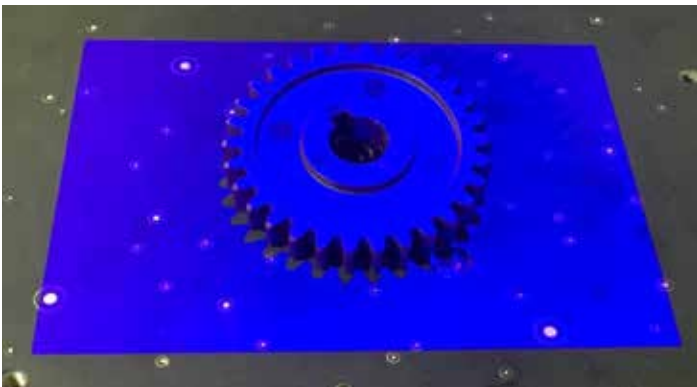

Figure 9: Optical scanning machine.

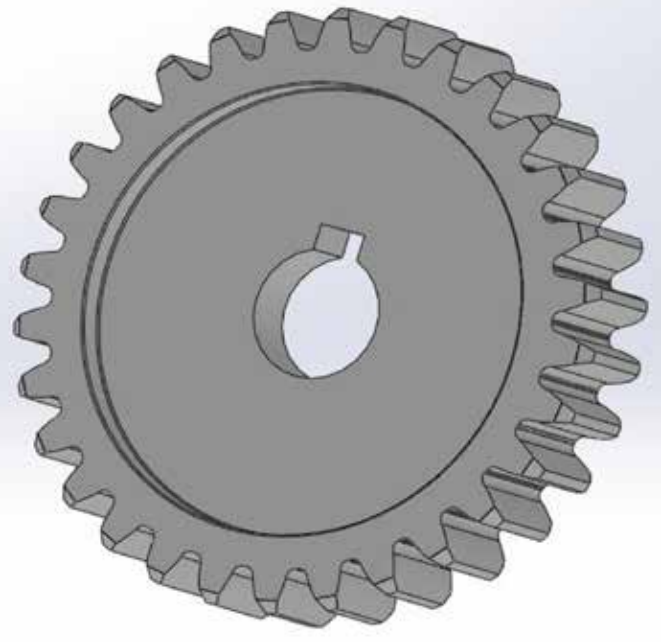

Figure 10: Result of optical scanning ("step" file).

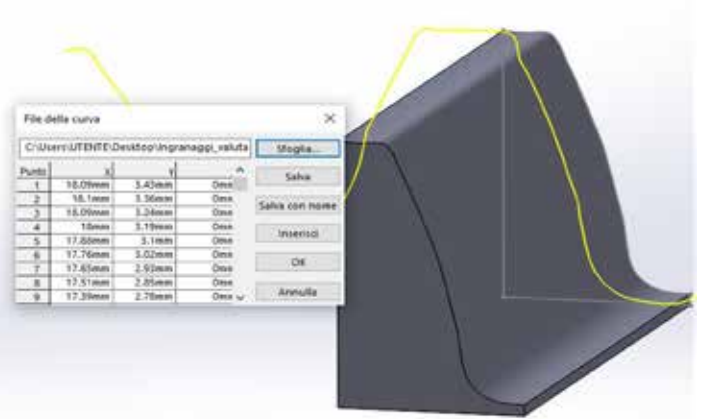

Figure 11: SolidWorks tooth form.

The test is carried out on gears with the same geometric characteristics (normal module, number of teeth, etc.). To get a statistical point of view, we carry out two tests under the same conditions (torque, speed, temperature).

5 WEAR CHECK

We check the wear behavior in two different ways: We compared the wear measured by the 3D optical scanner and by component weighing. Also every 3x10⁶ (3 million) cycles, we stop the test, do a visual check and Wildhaber measurement of the teeth on board the machine, then we restart the test. The gears are mounted again on the test bench with the same tooth in contact as before. (See Figures 5 and 6)]

6 BASIC GEAR MEASUREMENT

In order to check the plastic gears, we analyze the gears as manufactured using two methodologies. In this article, we use these symbols following the ISO/TR 10064 [4]. (See Table 3)

Contact machine: Using a machine Zeiss 3D PRISMO 7 with rotary table and gear software, we investigate the gearing parameters, geo-

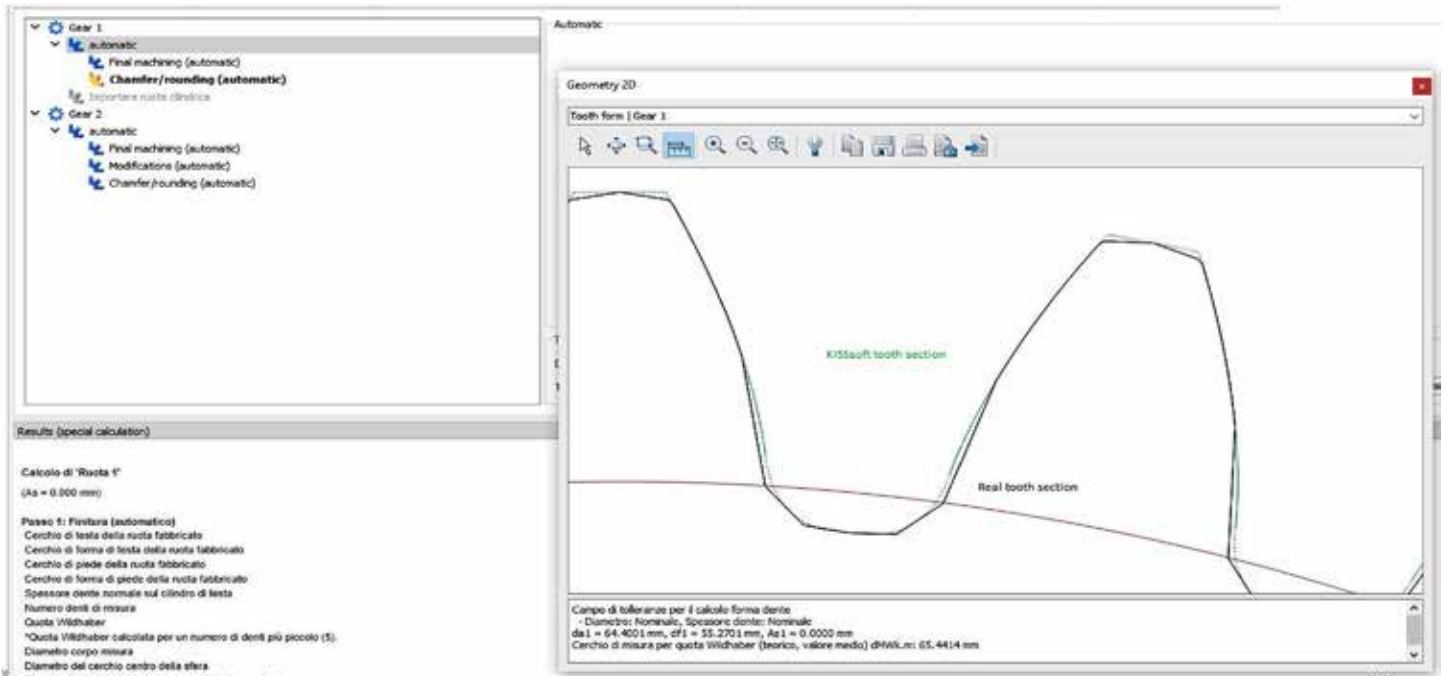

Figure 12: KISSsoft tooth form.

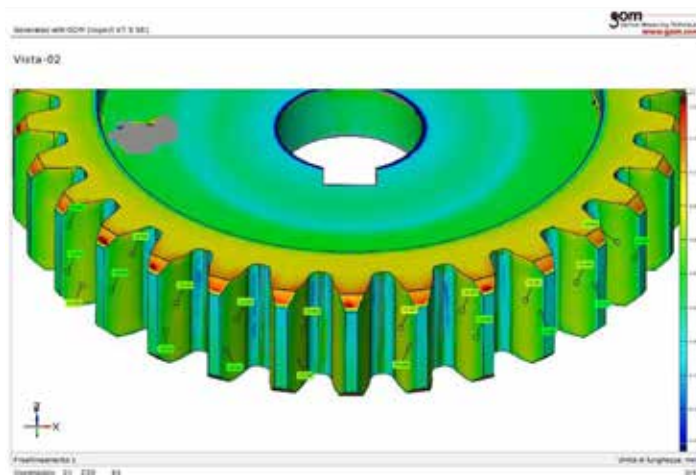

Figure 13: 3D Chromatic map.

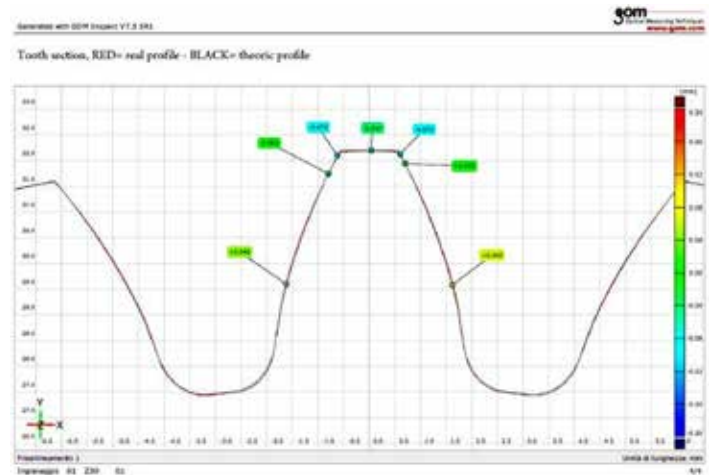

Figure 14: 2D section of chromatic map.

The chemical stability of the polymer compound in presence of the lubricating grease in temperature is important to ensure continued high mechanical and fatigue properties over the gear lifetime.

metric analysis of the flank, the profile, and the pitch with standard reports. We use the accuracy grade following ISO/DIS 1328-1 [5]. This standard establishes a tolerance classification system relevant to manufacturing and conformity assessment of tooth flanks of individual cylindrical involute gears. This is an extract of a Zeiss report that indicates the quality of gear 11 because the gears are molded with a prototype mold. (See Figures 7 and 8)

Non-contact machine: With an optical scanning machine ATOS Q, we acquire the 3D surface of the gear in “.stl” format for a subsequent

comparison with the mathematical 3D CAD “step” model by means of a chromatic map of deviations and subsequent digitization of the first 3D reference surface corresponding to the new gear. (See Figures 9 and 10)

We build a model for calculations of the real gear following these steps:

1: Acquire the gear before the test (teeth surface without wear effect). The output of the scanning is a file “.stl” format of the entirely surface of the gears. Using the CAD software SolidWorks, we import the “.stl” file, and we manage it to a draw section of a single tooth in a “.dxf” file. (See Figure 11)

2: Using the KISSsoft software, we insert the data of macro geometry for the standard report of a control machine (ZEISS). We import the “.dxf” section of a single tooth in KissSoft to create a “ideal” gear made from the “real teeth section,” after we export the “real gear” in the “.step” format. (See Figure 12)

3: With the “GOM Inspect” software, we compare the “real” 3D image of the gear with the “ideal” 3D model of the gear to do the best fit.

This is a chromatic map of the superimposition from 3D optical

Component	GEAR #1 before the test
First weighing [g]	31.46409
Second weighing [g]	31.46400
Third weighing [g]	31.46410
Average [g]	31.46406

Component	GEAR #2 before the test
First weighing [g]	31.47275
Second weighing [g]	31.47273
Third weighing [g]	31.47272
Average [g]	31.47273

Table 4: Component weighing before the test.

scanning and the 3D KISSsoft model built with a “tooth form” tab. Finally, we have the 3D model with the “best fit geometry” to use for the FEM analysis.

The actual gear profiles differ a maximum 0.05-0.06mm more than the ideal calculate involute.

It would be interesting to use the same procedure to evaluate the tooth profile of steel gears but this is not the subject of this research.

These real profiles will be compared during the test to analyze the wear advancement. (See Figures 13 and 14)

4: Component weighing, with resolution of 0.01 mgm, the gear was blown with compressed air and then conditioned in an oven at 40°C for 30 minutes, then finally stabilized in a desiccator for 15 minutes and weighed.

Table 4 shows the average weight of the two gears before the test (0 cycles). The formula of average is seen in Equation 1: where

$$Average [g] = \sum_{n=1}^3 g_n / n$$

Average [g] is the average weight of the gear.
 g_n is the weight of the n-weighing.

7 DATA ACQUISITION

Our kind of test is a long-life test. We want to check the behavior of the gear until it fails. In order to perform it, we use a steel gear as the driving gear and the plastic gear as a driven gear in grease lubrication conditions [6].

The input conditions where the test rig must maintain constant are:

- ▶ Input torque: 10Nm.
 - ▶ Input speed: 1,000 rpm.
 - ▶ Teeth temperature of plastic gear: 100°C.
- The data that we want to collect are:
- ▶ Grease temperature [°C].
 - ▶ Number of cycles [-].



Figure 15: Test rig setup.

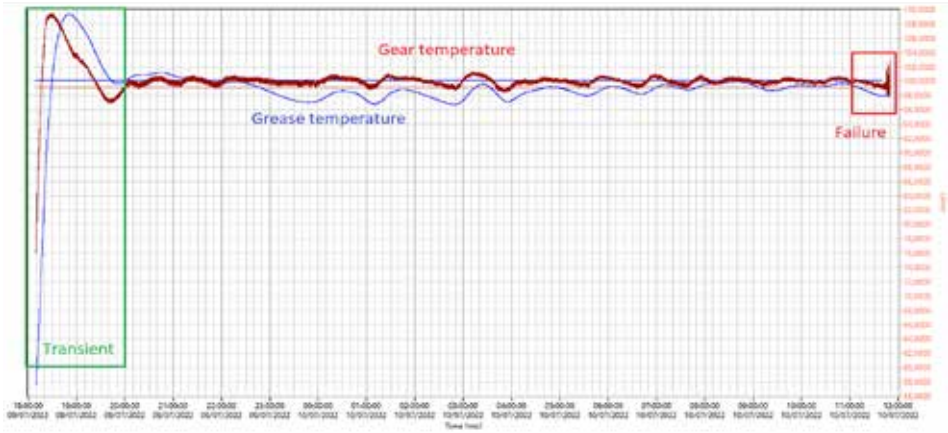

Figure 16: Temperatures graph.

	Cycles [-]	Failure	Gear Temperature [°C]	Std. Dev.
GEAR#1	10.059.222	Tooth root breakage	100.33	1.51
GEAR#2	9.272.959	Tooth root breakage	100.32	1.31

	Grease Temperature [°C]	Std. Dev.	Torque on gear 2 [Nm]	Std. Dev.
GEAR#1	99.29	2.95	10	0.03
GEAR#2	99.14	2.78	10	0.03

Table 5: Test results.

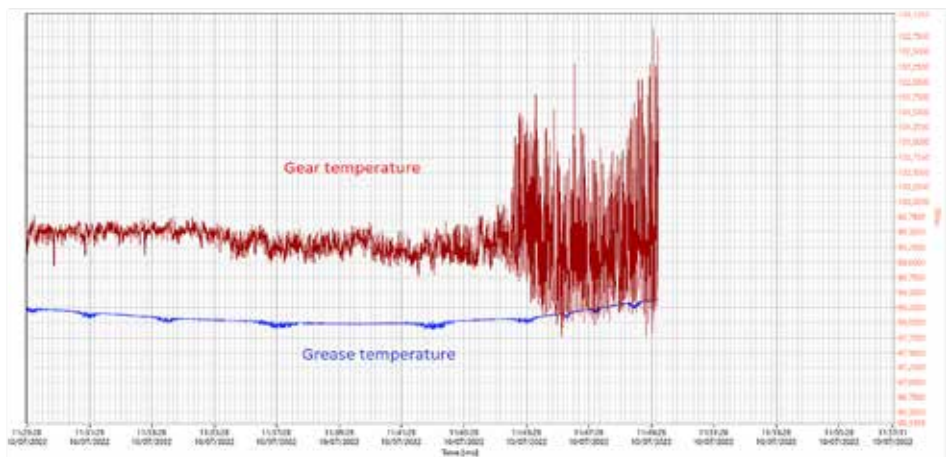

Figure 17: Temperature at the fail.

- ▶ Wildhaber measurement of the gears every 3×10^6 million cycles [mm].

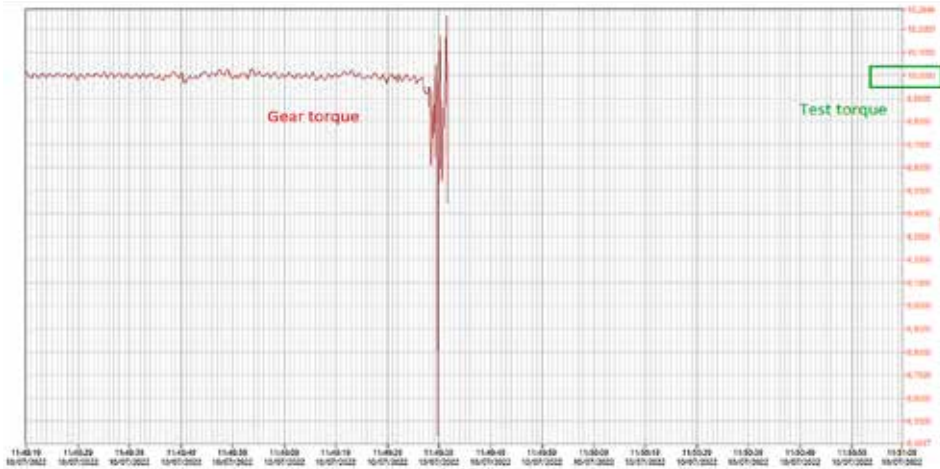

Figure 18: Torque graph at the failure.

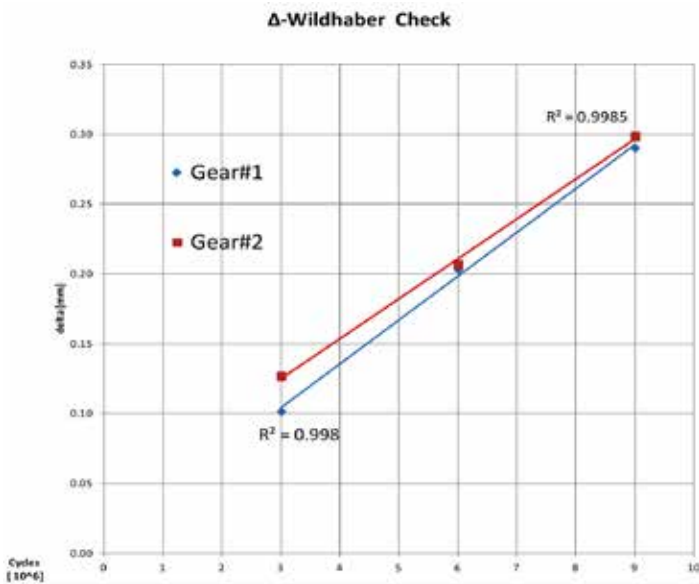

Table 7: Plot of delta Wildhaber measurements.

► 3D optical scanner analysis and gear weighing [gr].

We perform a test on two gears (GEAR#1 and GEAR#2) in order to have a statistical point of view.

8 TEST RIG SETUP

To reproduce this application, we built an aluminum housing. In this housing, we inserted the gears and then the entire system was placed inside a climate chamber.

In the aluminum box we have installed a PT100 in order to check the grease temperature during the test.

A thermal IR camera is used to maintain the gear temperature

and signal temperature retrofitting. This signal is sent to the climate control software to maintain the temperature value on the tooth surface of 100°C by heating or cooling the atmosphere inside the climate chamber in a close loop.

The electric motors are equipped with encoders for speed monitoring and two torque transducers are installed on the input and output shafts.

The test starts with the warm-up phase, in which the gears rotate at 60 rpm with a torque of 0.5 Nm. Once the teeth temperature of 80°C is reached, the test phase begins in which the gears accelerate to 1,000 rpm and a torque of 10Nm with an acceleration ramp defined by the author. In this way, we do not thermally stress the gears and do not introduce mechanical factors that could compromise the test.

A sensitive system for measuring torque and gear speed stops the test when the fault occurs. (See Figure 15)

9 TEST POST PROCESSING RESULTS

In Table 5, one can see the failure cycles on the gear test: The failure was a tooth root breakage.

The picture shows the grease and gear temperatures. We observe the transition phase in which the temperature rises up to 110°C and then the temperature reaches thermal equilibrium in two hours.

During the phase test, the grease temperature followed the thermal behavior of the gear temperature. At the end of the test, the average grease temperature was 99°C and the average gear temperature 100°C, demonstrating the good quality of the grease. (See Figure 16)

Figure 17 shows the temperature behavior when the fault occurs.

Then we checked GEAR#1 and GEAR#2 every 3×10^6 (3 million) cycles. During this phase, we carry out a visual control and a Wildhaber measurement of the tooth on the test rig. The gears are mounted again on the test bench with the same tooth in contact as before. (See Figure 18)

Every 3×10^6 cycles, we measured the same teeth three times and calculated the average Wildhaber measurement. (See Table 6)

If we plot the difference between the Wildhaber measurement of the test and the Wildhaber measurement of the previous gear test (GEAR#1 and GEAR#2) against load cycles, we obtain a straight line with a linear correlation of approximately $R^2=0.99$.

The graph in Table 7 shows a linear relationship of the wear rate with the number of cycles.

We also measured the weight of the gears after thorough washing to remove all contamination. The loss weight is done by the wear process that removes the plastic gear material.

GEAR#1 has reduced in weight by 1.25861 grams; GEAR# 2 shrunk

N° Gear	Before the test				3 millions cycles				6 millions cycles			
	1	2	3	Average	1	2	3	Average	1	2	3	Average
	W on z=5 teeth [mm]				W on z=5 teeth [mm]				W on z=5 teeth [mm]			
1	27.37	27.36	27.35	27.36	27.259	27.259	27.258	27.26	27.156	27.158	27.157	27.16
2	27.35	27.35	27.32	27.34	27.28	27.18	27.18	27.21	27	27.3	27.1	27.13

N° Gear	9 millions cycles				10 millions cycles			
	1	2	3	Average	1	2	3	Average
	W on z=5 teeth [mm]				W on z=5 teeth [mm]			
1	27.03	27.08	27.1	27.07	27.07	27.08	27.07	27.07
2	27.05	27.04	27.04	27.04				

Table 6: Wildhaber measurements.

Component	GEAR #1 before the test	GEAR #1 after 6 million cycles	GEAR #1 failure
First weighing [g]	31.46409	31.17290	30.20547
Second weighing [g]	31.46400	31.17281	30.20545
Third weighing [g]	31.46410	31.17283	30.20544
Average [g]	31.46406	31.17285	30.20545

Component	GEAR #2 before the test	GEAR #2 failure
First weighing [g]	31.47275	30.13715
Second weighing [g]	31.47273	30.13711
Third weighing [g]	31.47272	30.13714
Average [g]	31.47273	30.13713

Table 8: Gear weight measurements.

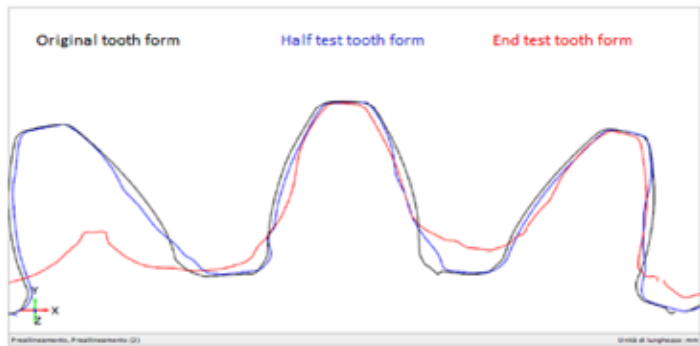

Figure 20: Behavior of the GEAR#1 final.

in weight of 1.33560 grams. (See Table 8)

From the formula in Equation 2 of the standard VDI 2736 part 2, we try to check the wear coefficient from the geometry and the degree of tooth loss.

$$k_w = \frac{W_m \cdot b_w \cdot z \cdot l_{Fl}}{T_d \cdot 2 \cdot \pi \cdot N_L \cdot H_v}$$

where

- W_m is the averaged linear wear.
- T_d is the nominal torque.
- b_w is the common face width.
- N_L is the number of load cycles.
- z is the number of teeth.
- H_N is the degree of tooth loss.
- l_{Fl} is the profile line length of the active tooth flank.

We obtained $k_w = 4.81 [10^{-6} \text{ mm}^3/(\text{Nm})] \pm 0.12$; this is an indicative value of the wear coefficient because it was very difficult to check the Wildhaber measurement on the gear affected from the wear.

With an optical scanning machine, we acquire the 3D surface of GEAR#1 at 6×10^6 cycles, and we compare this gear geometry with the original geometry before the test.

It appears the material is transported from the top (tip diameter) of the gear to the root area. (See Figures 19 and 20)

Figure 21 shows an example of an acquired chromatic map.

The post-mortem optical analysis of the IXEF® PARA gear in Figure 22 shows each tooth is worn out on their curved side. All teeth present transversal micro fractures at the bottom of the flank. It indicates the

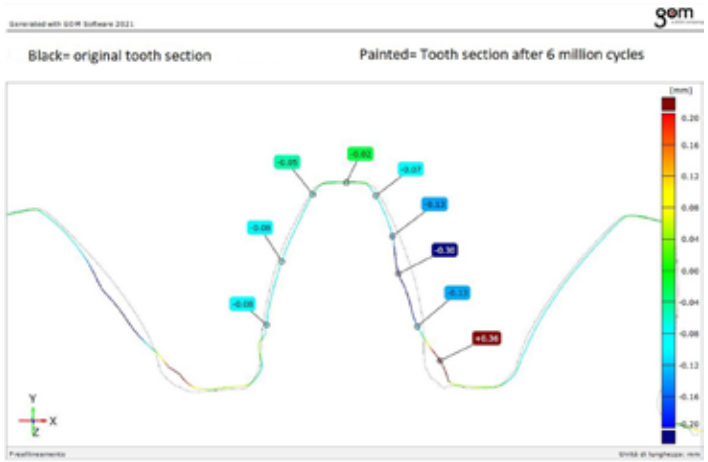

Figure 19: Behavior of the GEAR#1.

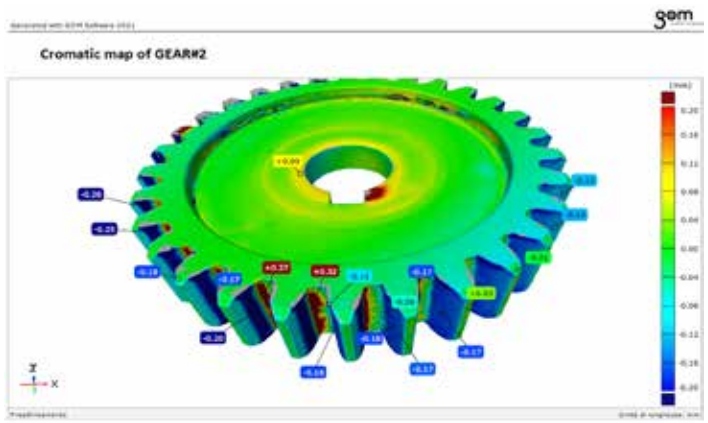

Figure 21: Chromatic map of GEAR#2.



Figure 22: Optical analysis.

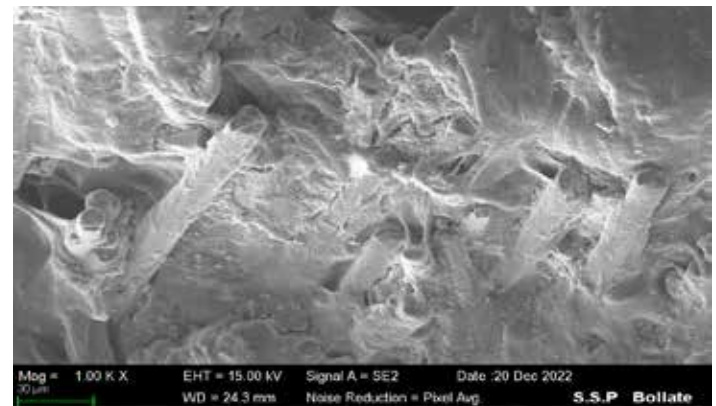

Figure 23: SEM analysis.

strain was homogeneously distributed.

The SEM analysis in Figure 23 shows the glass fibers in the worn gear maintain a residual layer of polymer on their surface, indicating a remaining good adhesion between the glass fibers and the polymer matrix. This is crucial to avoid early crack initiation and propagation in the polymer compound that can lead to early failure in gear application. The good properties of the IXEF® PARA compound allowed reaching a long lifespan of 10 million cycles.

10 CONCLUSIONS

The methodology used to characterize the performance and wear behavior of a polymer compound gave an interesting outcome. The wear coefficient of the polymer compound in gear tests was determined by weight and Wildhaber measurements. In addition, the optical scans combined with the optical microscopy analysis at the end of the test gave a good indication of the way the teeth were worn and deformed during the test.

The IXEF® PARA compound showed good gear performance at 100°C under the testing conditions, reaching 10 million cycles. No major wear on the tooth flank was observed in this test that was conducted in the presence of a lubricating grease. Finally, since the impact of the grease on material performance is negligible, we could correlate any wear measured to the progressive fatigue deterioration coming from the gear rotation.

ABOUT THE AUTHORS

Dr. Riccardo Longato is with Longato Riccardo Srls. Eng. Christine Hamon and Eng. Stefano Montani are with Solvay Specialty Polymers Italy S.p.A.

The tests confirmed the superior performance of Ixef® PARA when tested in contact with grease at high temperature. Such an achievement is opening the way to a new set of applications, for which temperature requirements become more challenging day after day.

11 ACKNOWLEDGEMENTS

A special thanks to UNILAB Laboratori Industriali s.r.l. for the support provided during the gear analysis phase. 🇮🇹

BIBLIOGRAPHY

- [1] S. Karl, "Progettare gli ingranaggi del futuro," presented at the MecSpe 2018, Parma, Mar. 2018.
- [2] AGMA, AGMA 920-A01: Materials for Plastic Gears. 2001.
- [3] VDI 2736-4: "Thermoplastic gear wheels — Determination of strength parameters on gears," 2016.
- [4] ISO/TR 10064-1, "Code of inspection practice — Part 1: Measurements of cylindrical gear tooth flank," 2019-09.
- [5] ISO/DIS 1328-1, "Cylindrical gears - ISO system of flank tolerance classification — Part 1: Definitions and allowable values of deviations relevant to flank of gear teeth," 2022.
- [6] R. Longato and M. Turci, "The effect of temperature on the SN curve for bending stress measured on a new test rig for plastic gears" presented at the International Conference on Gears 2021, Garching, 2021.

YOUR FREE SOURCE FOR GEAR INDUSTRY NEWS

Gear Solutions magazine has been the most trusted source for information and technical knowledge in the gear manufacturing industry for more than 20 years.

Each issue, Gear Solutions offers its readers the latest, most valuable content available from companies, large and small, as well as critical thoughts on what this information means for the future of the gear industry. Best of all, it's **FREE** to you. All you need to do is subscribe.



On GearSolutions.com, we have paired our vast technical archives with the latest web technologies to develop the most efficient, streamlined, user-friendly web experience in the gear industry.



SUBSCRIBE FOR FREE
Use the QR code or go to
www.gearsolutions.com

GEAR Solutions